

SECTION VIEW

PLANTER MUST BE FILLED WITH MIN 12" CLEAR STONE AND FILTER CLOTH BELOW BEDDING SOIL

TYPICAL 1 1/4" DRAINAGE HOLE, ENSURE HOLE IS ALWAYS CLEAR AND FUNCTIONING

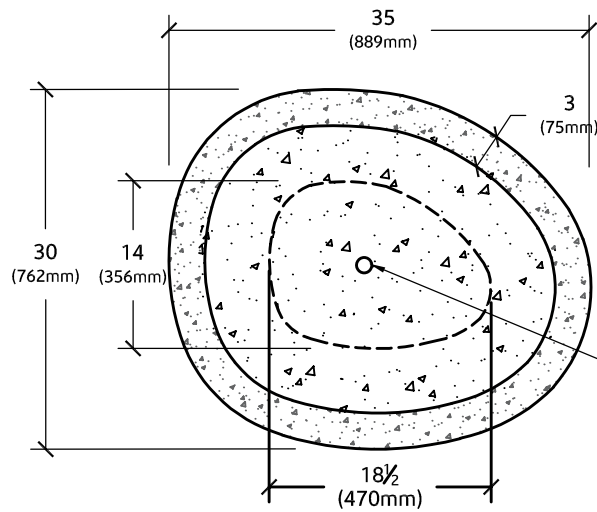

PLAN VIEW

TYPICAL CAST IN 1 1/4" DRAINAGE HOLE

NOTES:

1. CONTRACTOR TO REFER TO ARCHITECTURAL SPECIFICATIONS FOR COLOUR, FINISH AND VALUE ADDED FEATURES
2. SUBMIT COLOUR AND FINISH SAMPLES FOR APPROVAL



WOK PLANTERS

W-353040

ED'S CONCRETE PRODUCTS
1266 ERIE STREET
STRATFORD, ONTARIO
N4Z 0A1

1-877-265-6590
www.edskoncrete.com
info@edsconcrete.com

